

CH0003 Battery Charger/Conditioner

Operation Manual



Equivalent to: NSN: 6130-01-499-7305

Ultralife Corporation
2000 Technology Parkway, Newark, NY 14513 USA

Telephone (315) 332-7100 FAX (315) 331-7800

E-MAIL: sales@ulbi.com

<http://www.ultralifecorporation.com>

Copyright

Copyright © 2010, Ultralife Corporation. All Rights Reserved.

Disclaimer of Liability

Information and descriptions contained in this manual are the property of Ultralife Corporation. Distribution and/or reproduction in part or in whole are expressly forbidden without written consent.

Ultralife Corp believes that information in this publication is accurate as of its publication date. Ultralife Corp. reserves the right to change the contents without prior notice and is not responsible for any inadvertent errors.

Ultralife Corporation
2000 Technology Parkway
Newark, New York 14513
Phone: (315) 332-7100
Fax: (315) 331-7800
Email: sales@ulbi.com
<http://www.ultralifecorporation.com/>

CONTENTS

CONTENTS	3
1 ABOUT THIS MANUAL	4
1.1 SYMBOLS USED.....	4
1.2 GENERAL SAFETY INSTRUCTIONS	5
2 PRODUCT DESCRIPTION	6
2.1 FEATURES.....	6
2.1.1 Charge Detection	6
2.1.2 Lithium Ion Battery Detection	6
2.1.3 NiCad OR NiMH Battery Detection	7
2.1.4 Temperature Detection.....	7
2.1.5 Unattended Charging	7
2.1.6 Wide Range Input Voltage	7
2.1.7 Conditioning Cycle	7
2.1.8 Product Name Plate	7
2.1.9 Equipment Provided	8
2.2 PHYSICAL DESCRIPTION.....	8
2.3 FUNCTIONAL DESCRIPTION.....	8
2.3.1 Charge Supply.....	9
2.3.2 Control/Filter Board	9
2.3.3 AC to DC Power Supply	9
3 OPERATION	10
3.1 GROUNDING CONNECTIONS	10
3.2 AC POWER CORD CONNECTIONS.....	10
3.3 BATTERY SELECTION, CHARGING AND CHARGE CYCLE.....	10
3.4 BATTERY DISCHARGE	11
3.5 START-UP	11
3.6 LED INDICATORS.....	11
3.6.1 “Battery Type” Indicator LEDs	13
3.6.2 “Charging” Indicator LEDs.....	13
3.6.3 “90% Charge” Indicator LEDs	13
3.6.4 “Discharge” Indicator LEDs	13
4 MAINTENANCE	14
4.1 CLEANING	14
4.1.1 Dirt and Dust	14
4.1.2 Oils and Grease	14
4.2 CORRECTIVE MAINTENANCE.....	14
5 CUSTOMER ASSISTANCE	15
5.1 WARRANTY INFORMATION	15
5.2 CONTACT/RETURN INFORMATION	15
6 SPECIFICATIONS	16

1 ABOUT THIS MANUAL

This manual has been prepared by Ultralife Corp for the purpose of providing a maintenance technician the information necessary to understand and to maintain the CH0003 Battery Charger/Conditioner.

1.1 Symbols Used

The symbols shown in this section appear throughout this manual, the first one shown being the NOTE symbol, below, which is self-explanatory.



NOTE: Note statements contain important information that may affect how you use this product.

The other symbols represent important safety advice, and they appear throughout this manual and on the CH0003 in the form of WARNINGS and CAUTIONS against possible hazards to people or equipment, respectively. These safety WARNINGS and CAUTIONS must be followed at all times.



WARNING: Warning statements mean danger. They identify practices, procedures or conditions such as high voltage that could result in injury or loss of life and which, therefore, require extreme care before proceeding.



CAUTION: Caution statements denote a hazard. They identify practices, procedures or conditions that could result in damage to or destruction of this product or other equipment or property.



Ground: This symbol is placed adjacent to grounding locations on the unit. These areas are designed to be connected to an earth ground either through a power cable or grounding cable to prevent injury to the user.



Ground: This symbol is placed adjacent to grounding locations on the unit. These areas are designed to be connected to an earth ground either through a power cable or grounding cable to prevent injury to the user.



Direct Current: This symbol is placed adjacent to the Direct Current (DC) input location on the unit. This connector is designed to be connected to only a DC source.



DC Polarity: These two symbols are placed next to their corresponding DC input connectors to identify positive and negative to the user. The “+” symbol indicates the red positive terminal, and the “-” symbol indicates the black negative terminal.

Ultralife Corp assumes no liability for the customer’s failure to comply with these WARNINGS and CAUTIONS.

1.2 General Safety Instructions



WARNING: Prior to using the CH0003, please read the safety and caution instructions located in this section to prevent the mischarge or catastrophic destruction of a battery.

While inherently safe, misuse of the CH0003 may result in damage to the battery and/or the CH0003 battery charger. Specifically:

- Before using the CH0003 battery charger, read all instructions and cautionary markings on (1) the battery charger, (2) battery, (3) product using the battery.
- **To reduce the risk of injury, charge only batteries this charger is designed to charge: BB-390/U / MAI-390 Nickel Metal - Hydride, UBI-2590 / BB-2590/U, UBBL09 Lithium Ion and BB-590/U / MAI-590 NiCad batteries. Attempting to charge other types of batteries may cause personal injury and/or equipment damage.**
- Do not operate the CH0003 if it has received a sharp blow, been dropped, or otherwise damaged in any way; take it to a qualified repair technician for servicing.
- Do not expose the unit to wet conditions (rain or snow) with the lid open.
- Use of an attachment not recommended or sold by the battery charger manufacturer may result in risk of fire, electric shock, or personal injury.
- To reduce risk of damage to electric plug or cord, pull by plug rather than cord when disconnecting charger.
- Make sure cord(s) is located so that it will not be stepped on, tripped over, or otherwise subjected to damage or stress.
- An extension cord should not be used unless absolutely necessary. Use of improper extension cord could result in risk of fire and electric shock.
- Do not operate the charger with damaged cord or plug—replace it immediately.
- Do not disassemble the CH0003; take it to a qualified repair technician when service or repair is required. Incorrect reassembly may result in a risk of electric shock or fire.
- To reduce risk of electric shock, unplug charger from its power source before attempting any maintenance or cleaning. Turning off controls will not reduce this risk.
- If there are any questions regarding maintenance or safety-of-use issues pertaining to the CH0003, please contact our service department at:

Service Department
Ultralife Corporation
(PHONE) (315) 332-7100 (FAX) (315) 331-7800
(Email) ucs@ulbi.com

2 PRODUCT DESCRIPTION

The CH0003 Battery Charger/Conditioner is designed to provide a safe and effective recharge of the following batteries:

- BB-390/U / MAI-390 Nickel Metal Hydride
- BB-590/U / MAI-590 Nickel Cadmium
- BB-2590/U Lithium-ion
- UBI-2590 Lithium-ion
- UBBL09 Lithium-ion

These batteries are rechargeable batteries commonly used with Tactical Communication Equipment. Each battery has the same form factor and in many cases is interchangeable for battery operated equipment. The CH0003 will charge up to six batteries at one time. Additionally, the user can charge multiple battery types at the same time.



CAUTION: Prior to using the CH0003, please read the safety and caution instructions located in section 1 to prevent the mischarge or catastrophic destruction of a battery.

While inherently safe, if the CH0003 is used incorrectly, an accident can occur. Misuse of the CH0003 may result in damage to the battery and/or the CH0003 battery charger.

2.1 Features

CH0003 features are described in the following subsections.

2.1.1 Charge Detection

The CH0003 automatically detects battery problems such as open cells or other battery problems, which prevent a safe and efficient charge. There are a number of internal safeguards built into the unit. Temperature, voltage and time are monitored throughout the fast charge. Fast charge is terminated when the unit detects the battery has been fully charged. The CH0003 also automatically detects different battery chemistries by the contacts or lack of contacts on the battery itself.

2.1.2 Lithium Ion Battery Detection

The charger detects the BB-2590 Li-Ion battery through the contact on the battery. When it is detected, the charger will charge using a constant current of 1.0A until the voltage reaches 16.4V. When the voltage is reached, the charger will go into a constant voltage mode. When the charge current falls below 140mA, the charge is complete. There is a 12-hour safety timer if the charge current never goes low enough. This will terminate the charge.

2.1.3 NiCad OR NiMH Battery Detection

With the lack of a contact, as with Lithium Ion batteries, the CH0003 will assume that the battery is a Nickel-based chemistry (NiCad or NiMH). The charger will charge at a constant current of 1A while sampling change in voltage. When a negative change in voltage is detected, the peak has been found and the charge is complete. There is a 6-hour safety timer that will terminate the charge if the battery never peaks. On the NiMH battery are thermistor contacts for each section that detect the battery's temperature.

2.1.4 Temperature Detection

If the battery's temperature is above 65°C when it is put on to charge, the charger goes into a fault condition and waits until the battery cools down before going into fast charge. If the battery gets above 65°C while charging, the charger will suspend the charge until the battery cools down, and then go back into fast charge to complete.

2.1.5 Unattended Charging

The Charge Modules, which detect open or shorted cells. If a defective cell is detected the CH0003 will not start the charge cycle.

Once Charge is completed the CH0003 will maintain the battery being charged with a trickle charge if battery is left connected to the CH0003

In no event will a battery be overcharged using the CHARGING ALGORITHM of the CH0003.

2.1.6 Wide Range Input Voltage

Allows for operation from nearly any AC or DC power source likely to be encountered worldwide.

2.1.7 Conditioning Cycle

Automatic discharge/recharge function included. The conditioning cycle can be activated individually per battery at operator's option.

2.1.8 Product Name Plate

Located on the top right hand side of the inside bezel plate is a product name plate that has the following information.

- Ultralife
- CH0003
- Serial Number
- Input Voltage Ranges
- Input Power and Current Ratings
- Contact Information
- CE Marking

An example of this plate is shown in Figure 1.



Figure 1: Name Plate

2.1.9 Equipment Provided

Provided with the CH0003 Charger/Conditioner is, an AC power cable and this technical manual.

2.2 Physical Description

The CH0003 is 635mm (25") L x 508mm (20") W x 229mm (9") D and weighs approximately 15kg (33 lbs.) Figure 2 shows the physical layout of the charger. The CH0003 consists of six charge modules, an AC to DC Power Module and a Control/Filter Board.



Figure 2: CH0003 Charger (Front View)

2.3 Functional Description

The CH0003 Charger (Figure 2) consists of the following items:

- Charge Module (6 ea.)
- Control/Filter Board
- AC to DC Power Supply

Each is described in the following subsections.

2.3.1 Charge Supply

The Charge Modules are non-repairable potted modules. These modules accept a DC input voltage, monitor battery selection and provide the charging functions for the battery to be charged. The battery detection circuit, discharge switches, battery charge indicator LEDs and charge circuitry are all located on these boards. Each module provides the necessary voltage/current parameters to the battery charge connectors.

2.3.2 Control/Filter Board

The Control/Filter Board accepts the AC and/or DC input power, contains self-resetting circuit breakers to protect the unit, filters for EMI suppression, a 5V regulator for charger modules and fan, and functions as the interconnect point between the charge modules and AC to DC Power.

2.3.3 AC to DC Power Supply

The AC to DC Power Module accepts a 115-230 VAC, 50/60 Hz AC input and converts the AC input to a regulated 25V DC output to the Charge Modules.

3 OPERATION

This section provides a basic operational description of the CH0003 battery charger and its assemblies/major components.

3.1 Grounding Connections

The CH0003 should be grounded to reduce risk of electric shock. The CH0003 is equipped with an electric cord having an equipment-grounding conductor and a grounding plug. The plug must be plugged into an outlet that is properly installed and grounded in accordance with all local codes and ordinances. The CH0003 is also equipped with an external earth ground stud and wing-nut. To prevent injury, it is required to use either the AC ground prong or the external ground stud for protection.

3.2 AC Power Cord Connections

If the plug will not fit into the outlet, have a proper outlet installed by a qualified electrician. A temporary adapter can be used to connect plug to a two-pole receptacle if a properly grounded outlet is not available. (See Specifications chapter for input power capabilities of the CH0003).



WARNING: Never alter AC cord or plug provided. Improper connection can result in a risk of an electrical shock. The temporary adapter should only be used until a properly grounded outlet can be installed by a qualified electrician.



WARNING: Before using adapter, ensure the center screw of outlet plate is grounded. The green colored rigid ear or lug extending from adapter must be connected to a properly grounded outlet. If necessary, replace original outlet cover plate with a longer screw that will secure adapter ear or lug to outlet cover plate and make ground connection to outlet.

3.3 Battery Selection, Charging and Charge Cycle

The CH0003 will charge six batteries at one time (including different battery chemistries or six of the same). Each battery's type will automatically be detected when placed on the charger. The CH0003 charge module allows the unattended recharge of batteries. The module also assures a safe and effective recharge of the battery. The charger has a built-in timer to shut off the CH0003 to prevent the battery from being overcharged. The recommended batteries are listed in the table that follows.

The typical charge cycle for the three types of batteries listed below assumes a fully discharged battery for the charge cycle. Note these are average (approximate) times and are listed to show a reasonable time frame for the charge cycle.



CAUTION: Prior to charging any rechargeable battery, verify the type of battery to be charged. The CH0003 consists of six charge modules and a Control/Filter Board. The CH0003 will safely and completely recharge UBI-2590, BB-2590, UBBL09 Li-ION, BB-390/U, BB-590/U, and UBBL02 batteries.

Battery	Description	Manufacturer	NSN	Charge Cycle
BB-390/U	Nickel Metal Hydride 12/24VDC	Bren-Tronics	6140-01-490-4317	4 hours
MAI-390	Nickel Metal Hydride 12/24VDC	Mathews & Associates		4 hours
BB-590/U	NiCad 12/24 VDC	Various		2.5 hours
MAI-590	NiCad 12/24 VDC	Mathews & Associates		2.5 hours
UBI-2590	Lithium-ion	Ultralife		6 hours
BB-2590/U	Lithium-ion	Bren-Tronics	6140-01-490-4316	6 hours
UBBL09	Lithium-ion	Ultralife		6 hours
UBBL02	UBI-2590 Lithium-ion	Ultralife	6140-01-553-3527	6 hours



NOTE: If a battery type is encountered which is not listed in the table above, please contact Ultralife Corp at the address or E-mail provided throughout this document.

3.4 Battery Discharge

The CH0003 allows the operator to discharge batteries. During the discharge function the top heat sink surface of the charger will become warm. This is normal operation. During discharge operation locate the CH0003 in a well-ventilated area and ensure no flammable materials are near the unit.

3.5 Start-up

The CH0003 automatically determines the battery type connected. The operator can either plug the CH0003 into a power source or attach the batteries to the unit first. Once the batteries are attached and power applied to the unit, the batteries automatically start charging.

3.6 LED Indicators

There are four groups of LEDs indicating the status of the charger. Refer to Figures 3 and 4 on the next page and the paragraphs that follow.

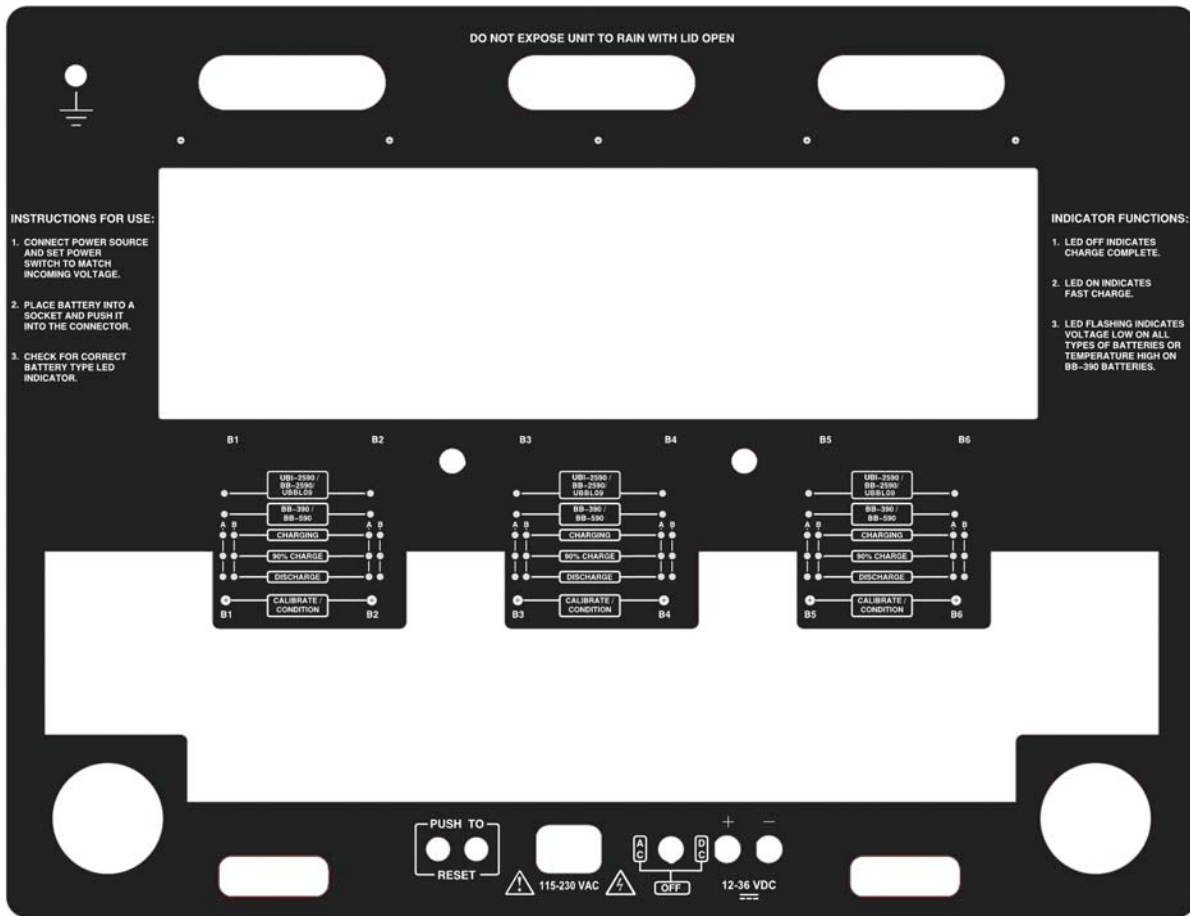

Figure 3 CH0003 Operation Panel

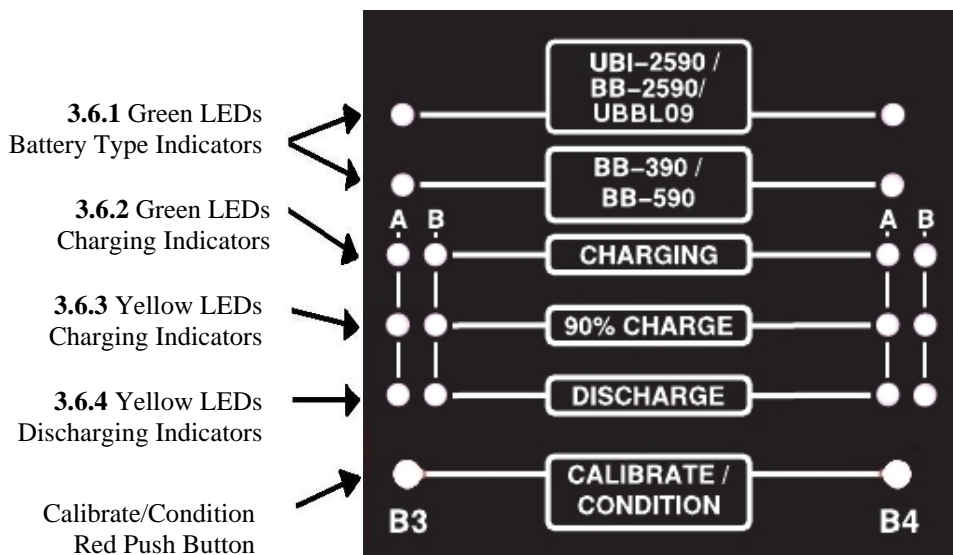

Figure 4 LED Indicators

3.6.1 “Battery Type” Indicator LEDs

When a battery is plugged in to the charger, one of the two green LEDs labeled "BATTERY TYPE" will indicate which type of battery (UBI-2590 / UBBL09 / BB-2590 or BB-390 / BB-590) is plugged in. When the correct type of battery is indicated, the battery will be charged correctly. If the incorrect type of battery is indicated, remove the battery from charger. The incorrect type of battery has been detected because of defect or damage to the battery contact, or damage to the charger. A battery that has been indicated as an incorrect battery will not charge correctly if left on the charger, and may cause damage to the battery or charger.

3.6.2 “Charging” Indicator LEDs

The two green LEDs labeled "CHARGING" indicate the state of charge a section of the battery is in. One indicator is for each section of the battery.

- Solid green: Indicates the battery is fast charging.
- Extinguished: Indicates the charge is complete.
- Blinking: Indicates a trickle charge condition. Trickle charge condition means the battery section voltage is too low or the battery section is too cold or too hot to fast charge. If a battery section's voltage is too low, or, is too cold (below optimum charging temperature) to charge, the charger will trickle charge until the voltage or temperature is high enough and then go into fast charge. If the battery section is too hot, the charger will wait until the section cools down before going into fast charge.

3.6.3 “90% Charge” Indicator LEDs

The two yellow LEDs labeled "90% CHARGE" indicate when the battery section is at least 90% full capacity. One indicator is for each section.

If the battery is charging and it is removed and then reinstalled back on the charger, the unit will restart the charge cycle.

3.6.4 “Discharge” Indicator LEDs

The two yellow LEDs labeled "DISCHARGE" indicate when the battery section is being discharged/conditioned. One indicator is for each section.

4 MAINTENANCE

Maintenance for the CH0003 is described in the following sections.

4.1 Cleaning

Cleaning of the CH0003 is described in the following sections.

4.1.1 Dirt and Dust

All external components to the CH0003 can be cleaned with a water dampened non-abrasive cloth and allowed to air dry or wipe dry with a clean dry non-abrasive cloth.

4.1.2 Oils and Grease

All external components of the CH0003 can be cleaned with a mild soap/water solution dampened non-abrasive cloth. Rinse with water dampened non-abrasive cloth and allowed to air dry or wipe dry with a clean dry non-abrasive cloth.

4.2 Corrective Maintenance

The CH0003 has NO user serviceable parts. Units requiring corrective maintenance should be sent to Ultralife Corporation for repair. Contact information is provided in the next chapter.

5 CUSTOMER ASSISTANCE

5.1 Warranty Information

Warranty Statement

4 years for equipment shipped after May 1, 2004.

3 years for equipment shipped prior to May 1, 2004.

Ultralife Corporation warrants to its customers that the products it manufactures and sells will be free from defects in materials and workmanship for a period of four (4) years for equipment shipped after May 1, 2004.

This warranty shall not apply to any defect, failure or damage caused by improper use or inadequate maintenance and care. Ultralife shall not be obligated to provide service under this warranty to repair, service, or modify these products.

In order to obtain service under this warranty, customers must return a failed unit to Ultralife Corp with a description of the failure, contact information (in case questions arise and to speed up processing of guarantee claims) and finally a return shipping address. Ultralife Corp will return any failed unit at Ultralife's cost.



NOTE: *This warranty does not apply to batteries supplied by Ultralife Corp. All batteries supplied by Ultralife Corp are warranted for one (1) year from date of shipment.*

5.2 Contact/Return Information

Please call (315) 332-7100 to obtain an RMA number prior to returning any failed unit(s) to:

*Ultralife Corporation
2000 Technology Parkway
Newark, New York 14513
Phone: (315) 332-7100
Fax: (315) 331-7800*

6 SPECIFICATIONS

Table 1: Physical Characteristics

Dimension	Measurement
Width	508mm (20 inches)
Length	635mm (25 inches)
Depth	229mm (9 inches)
Weight without Battery	15kg (33 lbs)

Table 2: LED Indicators

Indicator	Meaning
Flashing Green	Pre-charge Condition
Steady Green	Fast Charge
Green LED Off	Fast Charge Complete

Table 3: Electrical Characteristics

Dimension	Measurement
DC Input Range	12-36 VDC auto ranging
AC Input Range	115-230 VAC 50/60 Hz
Charge Rate	1.0 Amp PER STRING (BB-390/590 Batteries) 1.0 Amp PER STRING (BB-2590 Batteries)



NOTE: The DC Input requires approximately 275 watts max. Input current will vary depending on the voltage. Ultralife Corporation recommends a minimum of a 16 AWG wire be used for the DC power cable.